

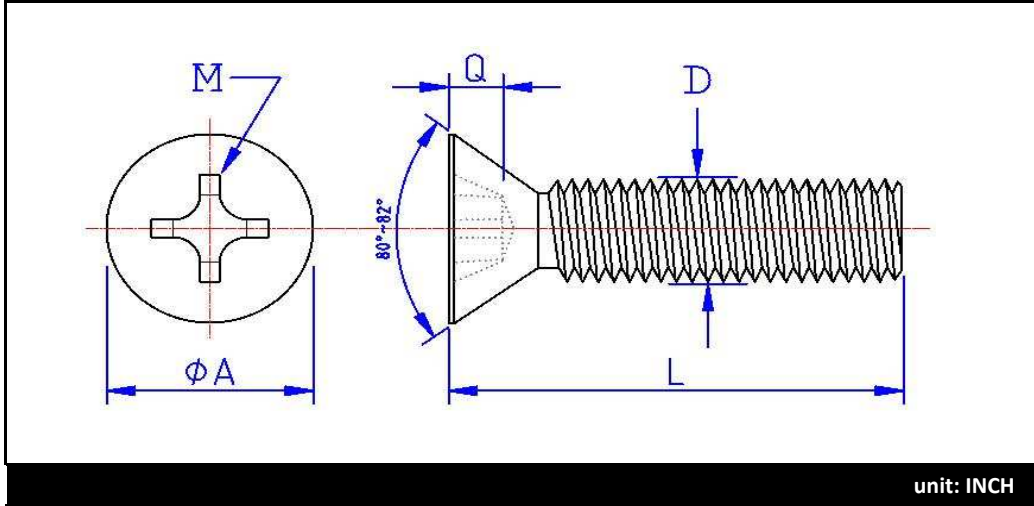

Brand	Root
	FPMS...



unit: INCH

L LENGTH TOLERANCE	$\leq 1/2''$	+0	-0,02
	$> 1/2''$ to $\leq 1''$	+0	-0,03
	$> 1''$ to $\leq 2''$	+0	-0,06
	$> 2''$	+0	-0,09

**FULL
THREAD**

Screw Size	M PUNCH		Q DRIVE DEPTH	A HEAD DIAM.	D THREAD DIAM.	THREAD PER INCH
# 6	# 2	Min	0.072	0,238	0,131	32
		Max	0.095	0,262	0.137	
# 8	# 2	Min	0.087	0,285	0,157	32
		Max	0.110	0,312	0.163	
# 10	# 2	Min	0.102	0,333	0,183	24
		Max	0.125	0,362	0,189	
# 10	# 2	Min	0.102	0,333	0,183	32
		Max	0.125	0,362	0.189	
1/4	# 3	Min	0.131	0,442	0,241	20
		Max	0.154	0,477	0,249	
5/16	# 3	Min	0.174	0,556	0,303	18
		Max	0.196	0,597	0,311	

**Flat Countersunk Head, Phillips, Machine screw
Stainless Steel (18-8) Passivated**

Root= Flat Phillips Machine Stainless

Bulk Label Description:

- English: FLAT HEAD, PHILLIPS, MACHINE SCREW, STAINLESS STEEL
- French: VIS MACHINE, TÊTE PLATE, CRUCIFORME, ACIER INOXYDABLE
- Spanish: TORNILLOS DE MÁQUINA, CABEZA PLANA, CRUCIFORME, ACERO INOXIDABLE

Date : 8 février 2019

Done by : P.B.