

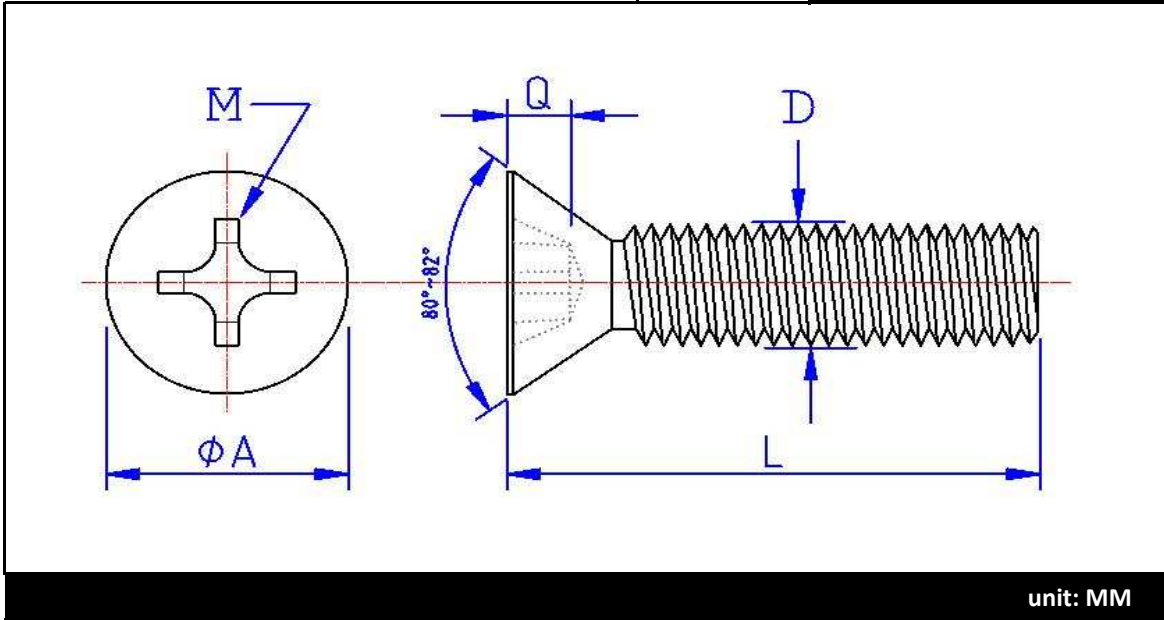

Brand	Root
	FPMZM...



unit: MM

L LENGTH TOLERANCE	≤ 13mm	+ 0	- 0.5
	> 13mm to ≤ 25mm	+ 0	- 0.7
	> 25mm to ≤ 50mm	+ 0	- 1.5
	> 50mm	+ 0	- 2.3

**FULL
THREAD**

Screw Size	M PUNCH		Q DRIVE DEPTH	A HEAD DIAM.	D THREAD DIAM.	THREAD PITCH MM
M4	# 2	Min	2.10	8.04	3.838	0.7
		Max	2.60	8.40	3.978	
M5	# 2	Min	2.70	8.94	4.826	0.8
		Max	3.20	9.30	4.976	

Root= Flat Phillips Machine Zinc Metric

Bulk Label Description:

- English: FLAT HEAD, PHILLIPS, MACHINE SCREW, ZINC
- French: VIS MACHINE, TÊTE PLATE, CRUCIFORME, ZINC
- Spanish: TORNILLOS DE MÁQUINA, CABEZA PLANA, CRUCIFORME, ZINC

Date : 28 février 2019

Done by : P.B.